

HYDROSTATIC FILLING LEVEL SENSOR HFB C4 / R / MD

Pressure measuring range 0-0.5 bar

Voltage supply 18–30 V DC

Features

- Filling level detection through measuring the hydrostatic medium pressure by means of blowing out a measuring hose or pipe (air bubbling technique)
- suitable for foaming medium types
- for filling level measurement up to a 5 m water column in pressure-free containers
- Alternative signal output interfaces (current loop / relay / Modbus RTU)
- Sensor without medium contact

Note

The display and control unit (Uni display) is required for setting the sensor in the relay and Modbus version.

www.asv-stuebbe.com/products/instrumentation

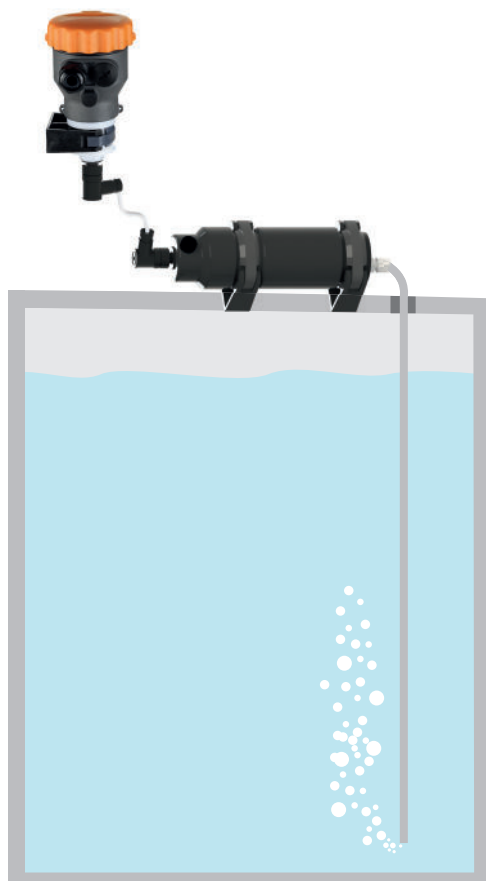

Hydrostatic filling level sensor HFB C₄ / R / MD

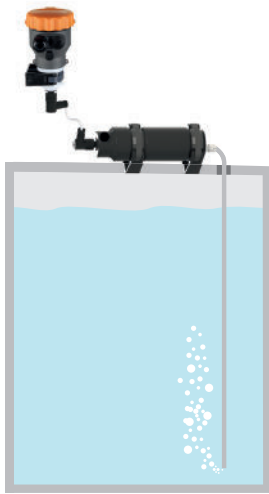

HFB Flex

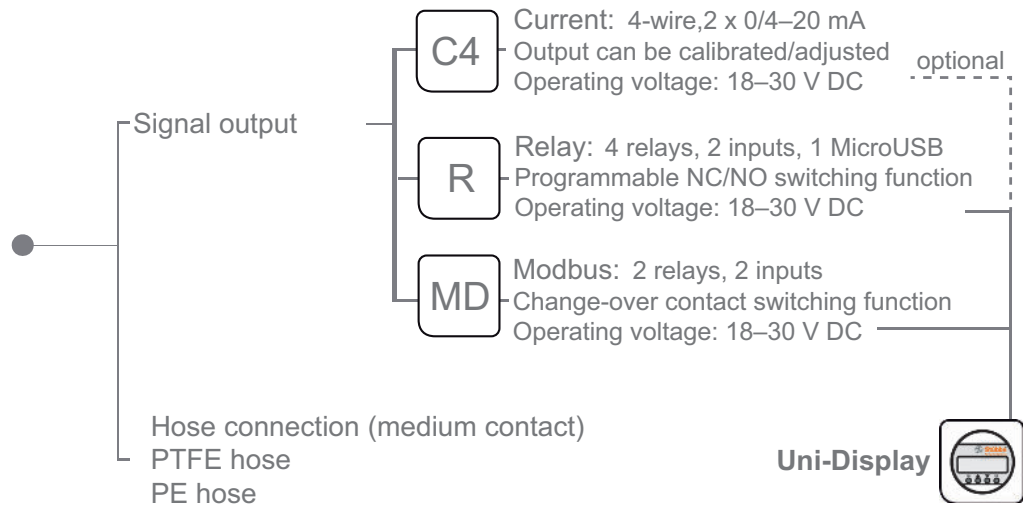

Sensor AL₂O₃ 96 % (no medium contact)

Hydrostatic filling level sensor HFB C₄ / R / MD

Application

The filling level sensor (type HFB) is a pressure transducer for filling level measurement according to the air bubbling technique. It measures the air pressure in a hose or pipe ending at the bottom of the tank, which matches the hydrostatic pressure at the bottom of the tank.

An integrated, electronically controlled air compressor maintains the hydrostatic pressure in the measuring pipe or hose.

Use

- Pressure transducer for filling level measurement for installation outside of the medium.
- Designed for measurements in fountains, basins and open or closed pressure-free containers.
- Comprehensive operating and display possibilities with relay, 0/4–20 mA signal output or Modbus RTU connection

Function

- The hydrostatic pressure or process pressure in the blown-out measuring pipe is registered by a ceramic transducer made of AL₂O₃.
The values are converted in the connection housing.
- The output values can be indicated by the UNI display and/or transmitted via the respective outputs.

• Versions

C₄:

The current module transmits the pressure level via standard 0/4–20 mA signals.

MD:

The Modbus module enables data bus communication. It contains two additional freely programmable relay outputs which can be used for directly intervening in the process if necessary.

R:

The relay module is equipped with four programmable relay outputs. It is particularly suitable for the direct control of sensitive plant components, e.g. for dry run protection of pumps.

Type

- HFB Flex with the connection housing separate from the sensor housing, connected by a 5 m long sensor cable and a compressor integrated in the sensor housing.

Interfaces

- Signal output, current loop (C₄):
0/4–20 mA
Output can be calibrated/adjusted
- Signal output, Modbus RTU (MD):
RS485
2 relays, 1 A / 30 V AC/DC
2 DC isolated inputs
- Signal output, relay (R):
4 relays, 5 A / 230 V AC
Programmable NC/NO switching function
2 inputs

Operation

- 4-wire current version (C₄):
using the integrated potentiometer,
optionally using the display and control unit (Uni display)
- Relay version (R):
using the display and control unit (Uni display)
- Modbus RTU version (MD):
using the display and control unit (Uni display),
relay / inputs via Modbus RTU

Measured variables

- Pressure (filling level)

Device connection

- 6x4 mm hose connection

Voltage supply

- U = 18–30 V DC

Cable connections

- Cable outside diameter: 5–11 mm
- Nominal cross-section, voltage supply: 0.25 mm²
- Nominal cross-section, relay outputs: 0.5 mm²
- Nominal cross-section, gate inputs: 0.25 mm²
- Nominal cross-section, Modbus: 0.35 mm²

Materials, wetted parts

- Hose, see accessories
- Hose weight: PVDF

Materials, not wetted parts

- Sensor: AL₂O₃ 96 %
- Sensor housing: PE
- Sensor seal: FPM
- Connection cable, sensor / display: TPE-V, UV-resistant
- Housing: PP-GF
- Housing cover: PP-GF / PA transparent
- Cover seal: NBR
- Housing fastening elements: PE

Weights

- Basic weight: 0.8 kg
- Additional weight: 1.2 kg

Type of protection

- IP 67

Output behaviour

- Power up: < 120 s
- Step response (10-90%) < 300 ms
- Integration time: 0-60 s, adjustable

Sensor data (pressure)

- Measuring range: 0-0.5 bar
- Precision at 0-85°C: ±0.2 % (after calibration basic correction, from maximum value)
- Resolution: 0.1 mbar

Ambient conditions

- Ambient temperature: -15-70 °C
- Atmospheric ambient pressure: 0.8-1.1 bar
- Relative humidity: 20-85 %

Process temperature

- according to the hose material used

Process pressure

- Atmospheric: 0.8-1.1 bar

Mounting position

- As required

Accessories

- PTFE hose 6x4 mm
- PE natural hose 6x4 mm
- Hose weight HFB
- Tank leadthrough 2"
- Display and control unit (UNI display)
- Additional weight

Display and control unit (UNI display)

- Can be used for all measuring instruments of the UNI display platform (PTM, HFT or UFM).
- Housing: ABS
- Cover: PA, transparent
- Display: illuminated LCD
- Operation: 4-key function
- Front film: polyester
- Data logger function with date stamp
- Firmware update possible
- Parameter settings can be saved and transmitted to other sensors.
- Storage function on a microSD card
- Battery: CR1220, 3 V
- The display unit can be removed from the sensor housing after the settings have been made.
- The display unit is required for setting the relay and Modbus version.



Hydrostatic filling level sensor HFB C₄ / R / MD

Ohmic resistance

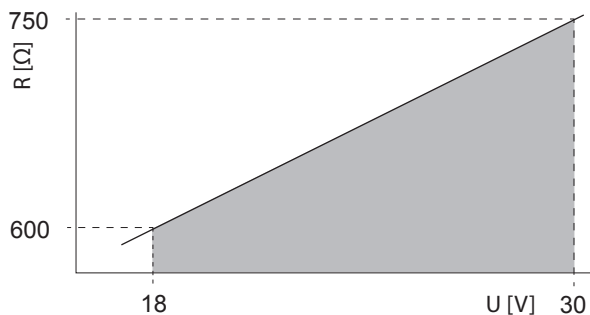

No.	Description
R	Max. ohmic resistance
U	Voltage supply

HFB Flex



No.	Description
1	Housing cover
2	Connection housing
3	Sensor housing with compressor
4	Mounting clip
5	Sensor cable
6	Mounting clip
7	6x4 mm hose connection
8	Air filter

Terminal connection plan, relay version

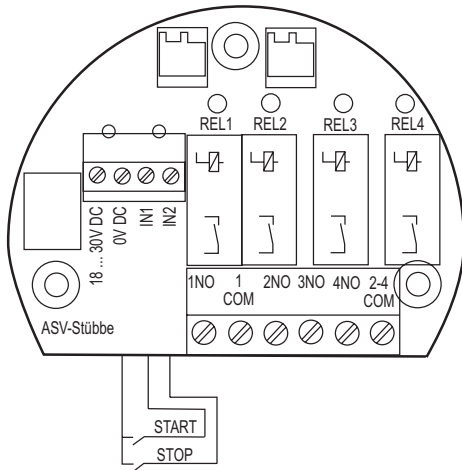

Terminal	Connection
18–30 V DC	Voltage supply (18–30 V DC)
0 V DC	Voltage supply (-)
1NO	Relay 1 normally open contact
1COM	Relay 1 COM
2NO	Relay 2 normally open contact
3NO	Relay 3 normally open contact
4NO	Relay 4 normally open contact
2–4 COM	Relay 2–4 COM

Terminal connection plan, 4-wire current version

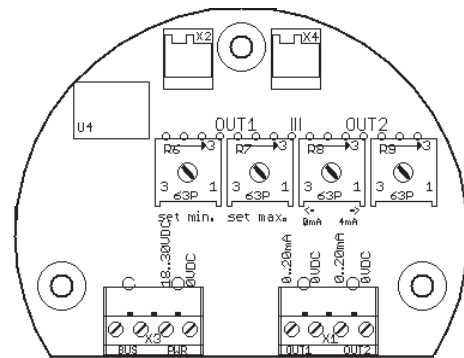

Terminal	Connection
Connector X₃	
PWR: 18–30 V DC	Voltage supply (18–30 V DC)
PWR: 0 V DC	Voltage supply (-)
Connector X₁	
OUT1: 0–20 V DC	0/4–20 mA pressure
OUT1: 0 V DC	Earth, pressure

Hydrostatic filling level sensor HFB C₄ / R / MD

Connection plan Modbus RTU Version

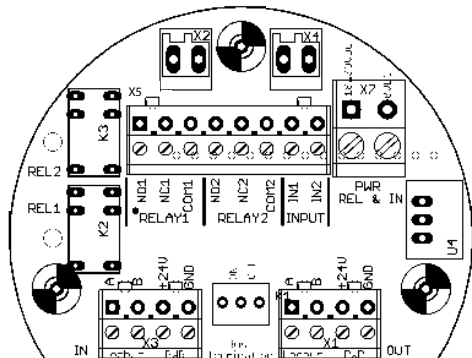

Terminal	Connection
Connector X2 / X4	
Plug-type connection	UNI display
Connector X5	
NO1	Relay 1 normally open contact
NC1	Relay 1 normally closed contact
COM1	Relay 1 COM
NO2	Relay 2 normally open contact
NC2	Relay 2 normally closed contact
COM2	Relay 2 COM
Connector X7	
PWR: 18–30 V DC	External voltage supply (inputs / relays)
PWR: 0 V DC	External earth
Connector X3 / X1	
A	RS485 A
B	RS485 B
PWR: +24 V	Operating voltage supply, sensor
PWR: GND	Operating voltage supply, sensor (earth)

Pin assignment, 5 pole

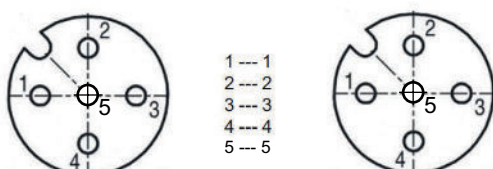

HFB Flex

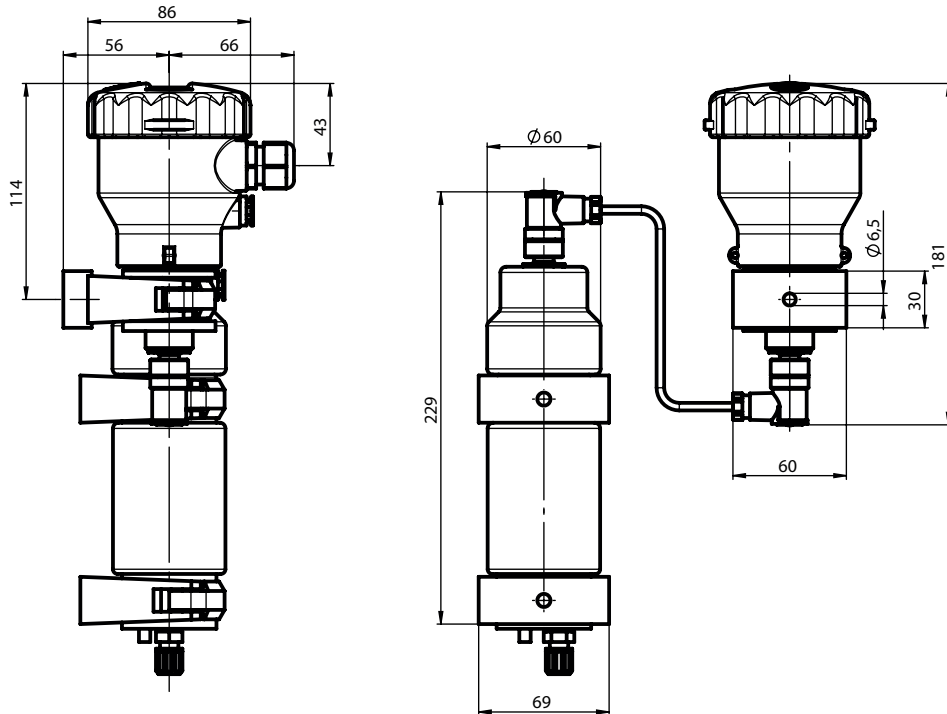

Tank leadthrough

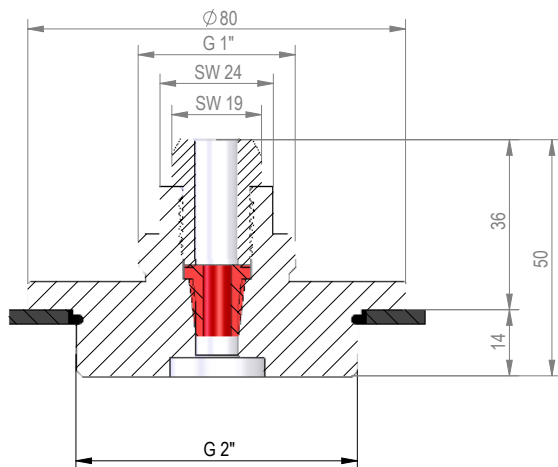

Additional weight

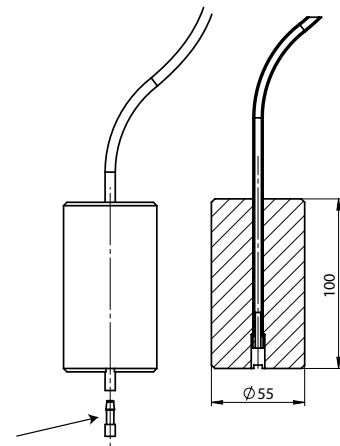

Installation of the additional weight:

- 1) Guide the hose through the hole in the additional weight.
- 2) Push the nipple into the hose.
- 3) Retract the hose.