

DIAPHRAGM VALVE MV 310

Nominal size DN 15–100

Nominal size 1/2"–4"

Pressure PN 6–10 bar



Features

- reliable valve with wide nominal size range
- good control characteristics
- high k_v value
- visual position display
(DN 15–50: as a standard, DN 65–100: optional)
- available as manual valve and with powerful pneumatic lift actuator

Additional options on request

- lift limitation
- manual emergency control

Accessories

- limit switch unit
- solenoid pre-control valve, position encoder

www.asv-stuebbe.com/produkte/armaturen



Pictogram Diaphragm valve MV 310

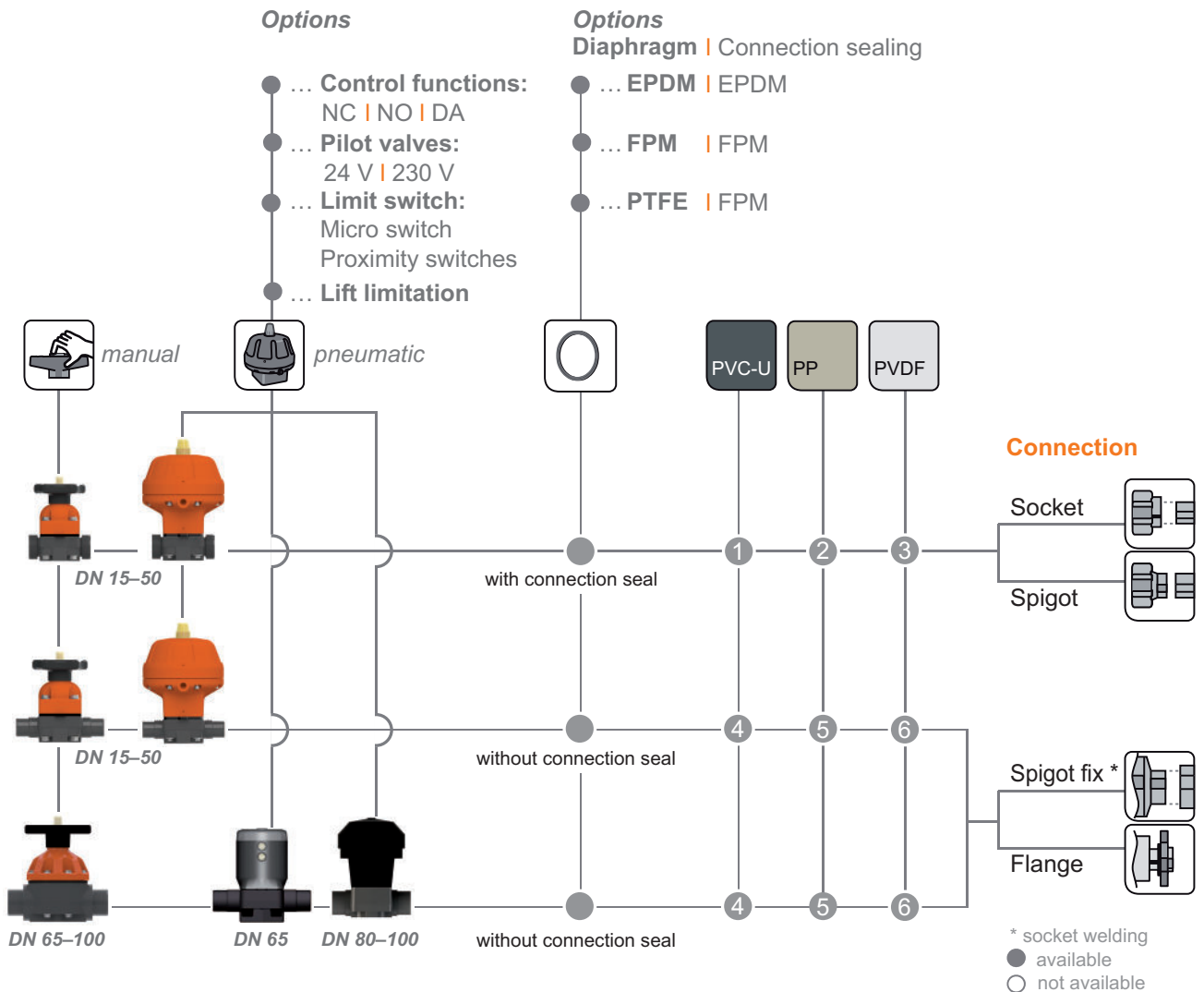

Basic Nominal Sizes:

DN 8	DN 10	DN 15	DN 20	DN 25	DN 32	DN 40	DN 50	DN 65	DN 80	DN 100	DN 125	DN 150	DN 200	DN 250	DN 300	DN 350	DN 400
------	-------	-------	-------	-------	-------	-------	-------	-------	-------	--------	--------	--------	--------	--------	--------	--------	--------

Connection Material (process connection)

<p>① PVC-U socket DIN, ANSI, BS, JIS female thread Rp 1.4571 female thread Rp male thread R PE100 spigot DIN</p> <p>② PP socket DIN female thread Rp PP spigot (IR) PE100 spigot DIN</p> <p>③ PVDF socket DIN PVDF spigot (IR)</p>	<p>④ PVC-U spigot fix * PP/St. flange DIN, ANSI GFK flange DIN **</p> <p>⑤ PP spigot fix * PP/St. flange DIN, ANSI GFK flange DIN **</p> <p>⑥ PVDF spigot fix * PP/St. flange DIN, ANSI</p> <p>* socket welding ** available in DN 15-50</p>
--	---

Diaphragm valve MV 310

Use

- Chemical plant manufacture
- Industrial plants
- Water treatment
- Electroplating plants

Application

- for shutting off pipelines and, to a limited extent, for control purposes in technical processing plants

Flow medium

- neutral and aggressive fluid or gaseous medium types, also with abrasive constituents, provided that the valve components coming into contact with the medium are resistant at the operating temperature in accordance with the ASV resistance guide.
- For nitric or sulphuric acid, please contact us and indicate the exact operating conditions!

Flow direction

- as required

ASV-Stübbe resistance guide

- www.asv-stuebbe.de/pdf_resistance/300051.pdf

Testing

- Requirements and testing according to DIN EN ISO 16138 and ISO 9393.
- Leakage rate A tested according to DIN EN 12266

Nominal pressure (H₂O, 20 °C)

With hand wheel:

- PN 10 bar

Pneumatic:

- PN 6–10 bar

Medium temperature

- See graphics „Pressure/temperature diagram“

Operating pressure

With hand wheel:

- See graphics „Pressure/temperature diagram“

Pneumatic:

- DN 15–50: max. 10 bar at 20 °C
- DN 65–100: max. 6 bar at 20 °C
- See graphics „Pressure/temperature diagram“

Material with medium contact

Housing:

- PVC-U, PP, PVDF

Diaphragm:

- EPDM, FPM, PTFE (EPDM diaphragm, PTFE coating on the medium side)

Sealing element:

- FPM, EPDM

Material without medium contact

With hand wheel:

Bonnet:

- PP glass fiber reinforced

Spindle:

- DN 15–50: Plastic (PA)
- DN 65–100: Steel (C1)

Spindle nut:

- Plastic (PA)

Hand wheel:

- Plastic (PA)

Pneumatic:

Bonnet:

- DN 15–50: PP glass fiber reinforced
- DN 65: PA-GR
- DN 80–100: Aluminum, coated

Size

- DN 15–100

Diaphragm valve MV 310

Actuation

With hand wheel:

- manually by means of an ergonomically shaped non-rising hand wheel

Pneumatic:

- with pneumatic lift actuator

Fastening

- via threaded inserts (metal inserts) in the valve body

Mounting position

- as required

Color

- Housing: PVC-U, gray, RAL 7011
- Housing: PP, gray, RAL 7032
- Housing: PVDF, opaque, yellowish-white
- Bonnet: orange, RAL 2004
- Bonnet: d75–110; red (pneumatic)
- GFK flange: black, RAL 9011
- PP/steel flange: black, RAL 9011

Device connection

- see pictograph „Diaphragm valve MV 310“

Pneumatic:

Control function

- NC (normally closed)
- NO (normally open)
- DA (double acting)

Control pressure

- DN 15–50: max. 6 bar at 20 °C
- DN 65: max. 7 bar at 20 °C (NC); max. 5 bar (NO/DA)
- DN 80–100: max. 6 bar at 20 °C

Lift limitation

- DN 15–50 (not suitable for the standard version):
It can only be used for the special version with the metal screw in the top section of the actuator. The lifting range is limited by turning the adjustment screw (3.30) clockwise.
- DN 65–100 special version: Order the actuator top section in the metal version for the NC valve. Please request separate instructions.

Diaphragm valve MV 310

Pressure/temperature diagram

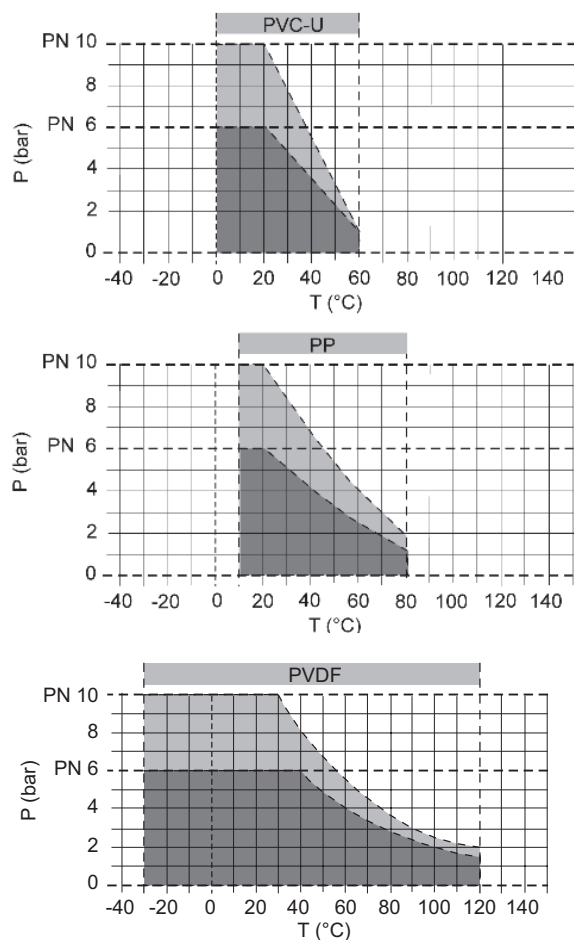

Description	
P	Operating pressure
T	Temperature

The pressure/temperature limits of the materials are valid for the stated nominal pressures and a service life of 25 years.

These values are guide values for flow medium types which do not negatively impact the physical and chemical characteristics of the valve material. It may be necessary to take diminution factors into consideration.

The operating life of the wear parts depends on the conditions of use.

Please note that, while PTFE has almost universal chemical resistance, the service life of PTFE-coated diaphragms may be reduced by medium types with a permeation tendency (e.g.: hydrofluoric acid, nitric acid, hydrochloric acid).

Pressure loss curve (standard values for H₂O, 20°C)

with hand wheel

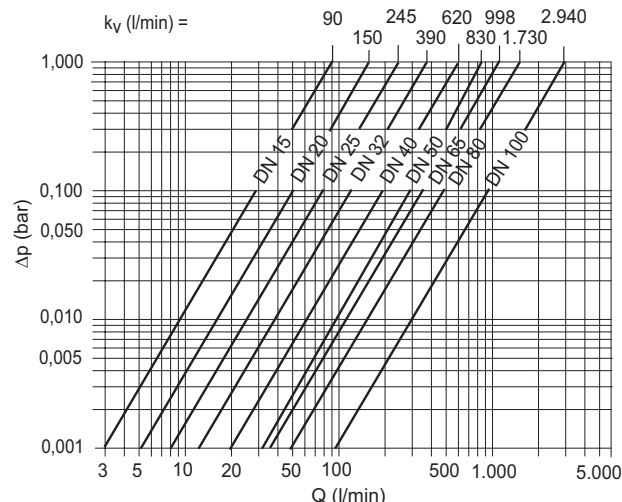

pneumatic

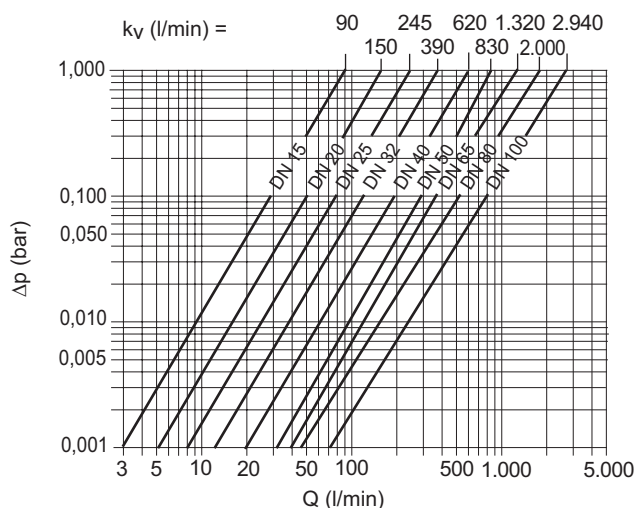

Description	
Δp	Pressure loss
Q	Flow

Pressure loss and k_v value

The diagram shows the pressure loss Δp in relation to the flow Q.

Conversion formulas

$$c_v = k_v \times 0.07$$

$$f_v = k_v \times 0.0585$$

Units

$$k_v \text{ [l/min]}$$

$$c_v \text{ [gal/min] US}$$

$$f_v \text{ [gal/min] GB}$$

Diaphragm valve MV 310

Flow characteristics

manual: DN 15–100

pneumatic: DN 15–50, DN 80, DN 100

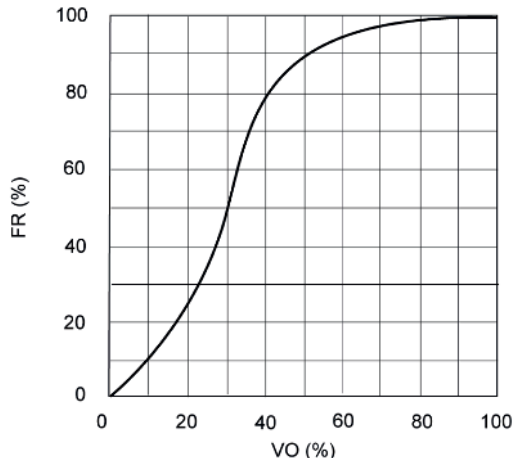

Flow characteristics DN 65

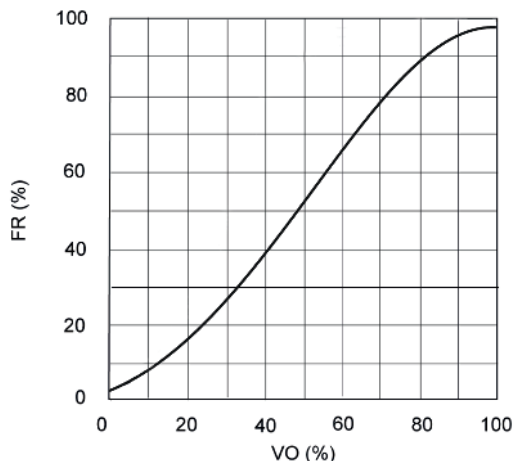

Description	
VO	Valve opening
FR	k_v value

pneumatic

Control curve DN 15–50 (d20–63)

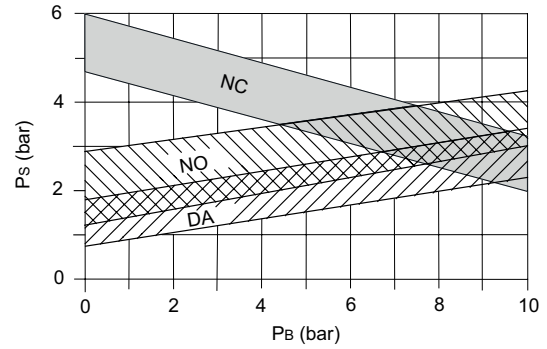

Control curve DN 65 (d75)

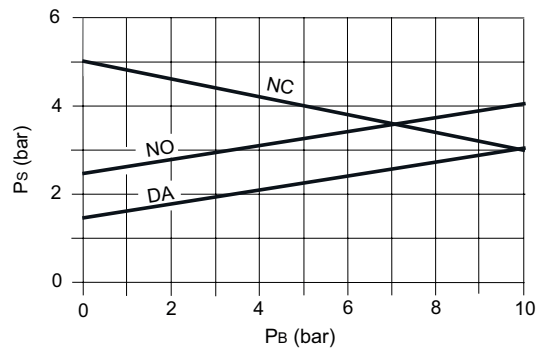

Control curve DN 80–100 (d75–110)

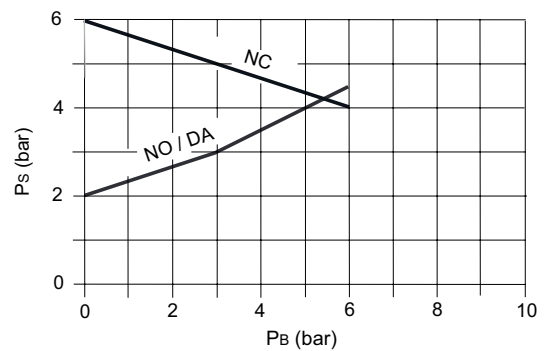

Description	
P _B	Operating pressure
P _S	Control pressure

Control pressure volume (standard liters)

d (mm)	20	25	32	40	50	63	75	90	110
NC	0.10	0.10	0.19	0.19	0.36	0.36	0.68	2.1	2.1
NO	0.08	0.08	0.19	0.19	0.42	0.42	0.79	2.2	2.2
DA	0.10	0.10	0.19	0.19	0.42	0.42	0.80	2.2	2.2

Diaphragm valve MV 310

**pneumatic:
NC control function**

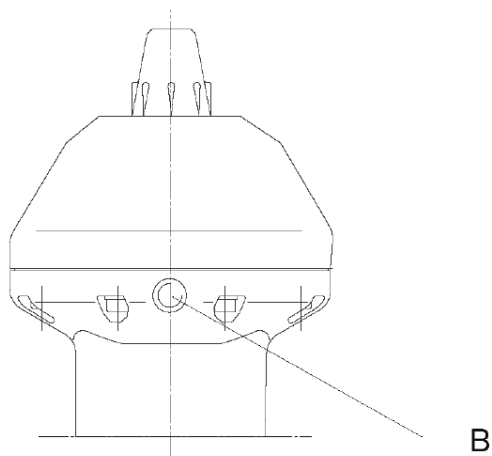

Connection B = 1/4"

Function	Control pressure open	
	Connection B	
Normally closed (NC)	»OPEN«	

NO, DA control function

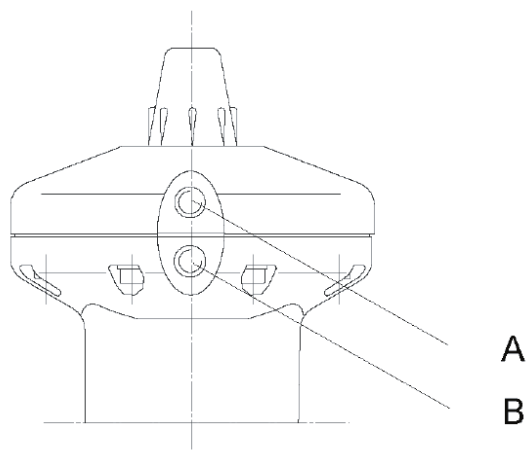

Connection A, B = 1/4"

Function	Control pressure open	
	Connection A	Connection B
Normally open (NO)	»CLOSED«	
Double-acting (DA)	»CLOSED«	»OPEN«

Diaphragm valve MV 310 with hand wheel

Connection socket

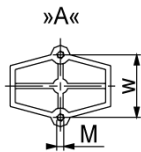
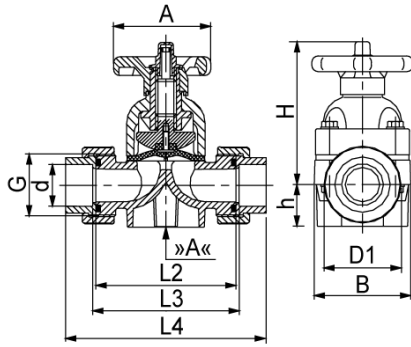

Connection spigot

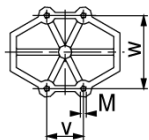
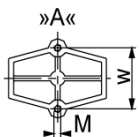
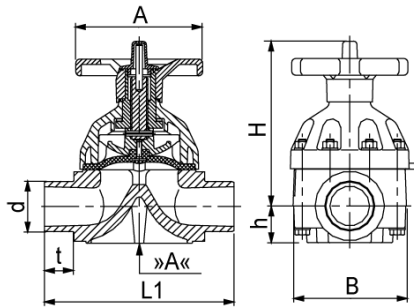

Connection flange

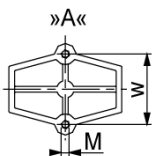
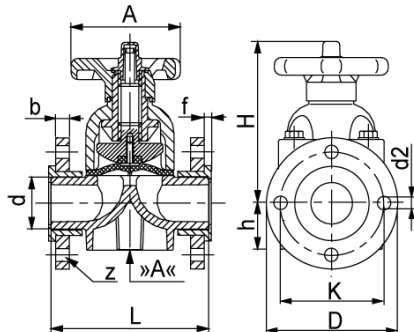

d (mm)	20	25	32	40	50	63	75	90	110		
DN (mm)	15	20	25	32	40	50	65	80	100		
DN (inch)	1/2	3/4	1	1 1/4	1 1/2	2	2 1/2	3	4		
A	90.0	90.0	100.0	100.0	130.0	130.0	190.0	190.0	240.0		
b	GFK flange DIN		12.2	14.0	15.0	17.0	17.0	18.5	18.5	20.0	22.0
	PP/st. flange ANSI		12.0	12.0	16.0	16.0	18.0	18.0	18.5	18.0	18.0
	PP/st. flange DIN		13.0	14.5	15.5	17.5	17.5	19.0	19.0	21.0	22.0
B	72.0	72.0	92.0	92.0	119.0	119.0	177.0	177.0	217.0		
d ₂	14.0	14.0	14.0	18.0	18.0	18.0	18.0	18.0	18.0		
D	95.0	105.0	115.0	140.0	150.0	165.0	185.0	200.0	220.0		
D ₁	PP		46.0	56.0	66.0	79.0	87.0	107.0	-	-	-
	PVC-U		41.0	50.0	58.0	72.0	79.0	98.0	-	-	-
	PVDF		47.0	57.0	64.0	78.0	89.0	109.0	-	-	-
f	6.0	7.0	7.0	8.0	8.0	9.0	10.0	11.0	12.0		
h	26.0	26.0	26.0	40.0	40.0	40.0	54.0	54.0	64.0		
H	98.0	102.0	131.0	135.0	169.0	175.0	245.0	245.0	285.0		
K	65.0	75.0	85.0	100.0	110.0	125.0	145.0	160.0	180.0		
L	130.0	150.0	160.0	180.0	200.0	230.0	290.0	310.0	350.0		
L ₁	124.0	144.0	154.0	174.0	194.0	224.0	284.0	300.0	340.0		
L ₂	90.0	108.0	116.0	134.0	154.0	184.0	-	-	-		
L ₃	96.0	114.0	122.0	140.0	160.0	190.0	-	-	-		
L ₄	PP		125.0	146.0	158.0	181.0	207.0	244.0	-	-	-
	PVC-U		128.0	152.0	166.0	192.0	222.0	266.0	-	-	-
	PVDF		128.0	150.0	162.0	184.0	210.0	248.0	-	-	-
M	M6	M6	M6	M8	M8	M8	M12	M12	M10		
t	PP		16.0	19.0	21.0	23.0	26.0	30.0	33.5	38.0	45.0
	PVC-U		16.0	19.0	22.0	26.0	31.0	38.0	44.0	52.0	61.0
	PVDF		16.0	19.0	21.0	23.0	26.0	30.0	33.5	38.0	45.0
v	-	-	-	-	-	-	-	-	60.0		
w	26.0	26.0	26.0	45.0	45.0	45.0	100.0	100.0	120.0		
z	4.0	4.0	4.0	4.0	4.0	4.0	4.0	8.0	8.0		

all dimensions in mm / * dimensions in inch

Diaphragm valve MV 310

pneumatic

Connection socket

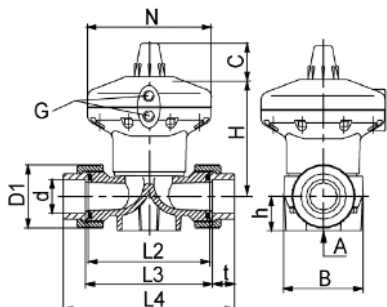

Connection spigot

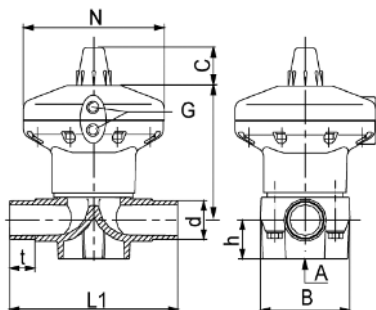

Connection flange

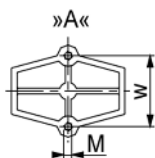
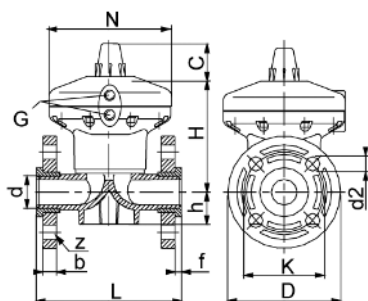

d (mm)	20	25	32	40	50	63	75	90	110	
DN (mm)	15	20	25	32	40	50	65	80	100	
DN (inch)	1/2	3/4	1	1 1/4	1 1/2	2	2 1/2	3	4	
b	GFK flange DIN	12.2	14.0	15.0	17.0	17.0	18.5	18.5	20.0	22.0
	PP/st. flange ANSI	12.0	12.0	16.0	16.0	18.0	18.0	18.5	18.0	18.0
	PP/st. flange DIN	13.0	14.5	15.5	17.5	17.5	19.0	19.0	21.0	22.0
B		72.0	72.0	92.0	92.0	119.0	119.0	-	-	-
C	NC	29.0	29.0	29.0	29.0	41.0	41.0	-	-	-
	NO	41.0	41.0	41.0	41.0	41.0	41.0	-	-	-
	DA	41.0	41.0	41.0	41.0	41.0	41.0	-	-	-
d2		14.0	14.0	14.0	18.0	18.0	18.0	18.0	18.0	18.0
D		95.0	105.0	115.0	140.0	150.0	165.0	185.0	200.0	220.0
D1	PP	46.0	56.0	66.0	79.0	87.0	107.0	-	-	-
	PVC-U	41.0	50.0	58.0	72.0	79.0	98.0	-	-	-
	PVDF	47.0	57.0	64.0	78.0	89.0	109.0	-	-	-
f		6.0	7.0	7.0	8.0	8.0	9.0	-	-	-
G*		1/4	1/4	1/4	1/4	1/4	1/4	1/4	1/4	1/4
h		26.0	26.0	26.0	40.0	40.0	40.0	46.0	55.0	64.0
H	NC	136.0	136.0	175.0	175.0	207.0	207.0	211.0	325.0	355.0
	NO	113.0	113.0	139.0	139.0	155.0	155.0	211.0	305.0	330.0
	DA	113.0	113.0	139.0	139.0	155.0	155.0	211.0	305.0	330.0
K		65.0	75.0	85.0	100.0	110.0	125.0	145.0	160.0	180.0
L		130.0	150.0	160.0	180.0	200.0	230.0	290.0	310.0	350.0
L1		124.0	144.0	154.0	174.0	194.0	224.0	284.0	300.0	340.0
L2		90.0	108.0	116.0	134.0	154.0	184.0	-	-	-
L3		96.0	114.0	122.0	140.0	160.0	190.0	-	-	-
L4	PP	125.0	146.0	158.0	181.0	207.0	244.0	-	-	-
	PVC-U	128.0	152.0	166.0	192.0	222.0	266.0	-	-	-
	PVDF	128.0	150.0	162.0	184.0	210.0	248.0	-	-	-
M		M6	M6	M6	M8	M8	M8	M8	M12	M12
N		122.0	122.0	152.0	152.0	192.0	192.0	144.0	258.0	258.0
t	PP	16.0	19.0	21.0	23.0	26.0	30.0	44.0	38.0	41.5
	PVC-U	16.0	19.0	22.0	26.0	31.0	38.0	44.0	52.0	61.0
	PVDF	16.0	19.0	21.0	23.0	26.0	30.0	44.0	38.0	41.5
w		26.0	26.0	26.0	45.0	45.0	45.0	44.5	100.0	120.0
z		4.0	4.0	4.0	4.0	4.0	4.0	4.0	8.0	8.0

all dimensions in mm / * dimensions in inch

Additional options Diaphragm valve MV 310

Limit switch

Limit switch



Limit switch design 1:
Nominal size DN 10–50



Limit switch design 2:
Nominal size DN 65–100

Attention

- Limit switch design 1:
for diaphragm valves MV 308 and MV 309
for diaphragm valve MV 310 for nominal size DN 10–50
- Limit switch design 2:
for diaphragm valves MV 310 for nominal size DN 65–100

Features

- high-quality materials
- reliable and low-maintenance

Application

- Limit switches for signaling »Open/Closed«

Diaphragm valve	Nominal size	Limit switch	
		Design 1	Design 2
MV 308	DN 12–15	X	
MV 309	DN 15–32	X	
MV 310	DN 15–50	X	
	DN 65–100		X

Housing

- Limit switch design 1: PVC-U
- Limit switch design 2: PP

Bonnet

- Limit switch design 1: PVC-U-transparent
- Limit switch design 2: PC (Makrolon)

Sealing element

- EPDM

Screws

- stainless steel (1.4301)

Electrical connection

- Cable connection, type 1: PG 16
- Cable connection, type 2: PG 13.5

Protection class

- IP 65

Options

Limit switches:

- Micro switch VCSP
- Inductive proximity switch NJ2-V3-N (NAMUR)
- Inductive proximity switch NBB2-V3-E2 (PNP)

Additional options Diaphragm valve MV 310

Limit switch

Technical data

Circuit diagram – Micro switch VCSP

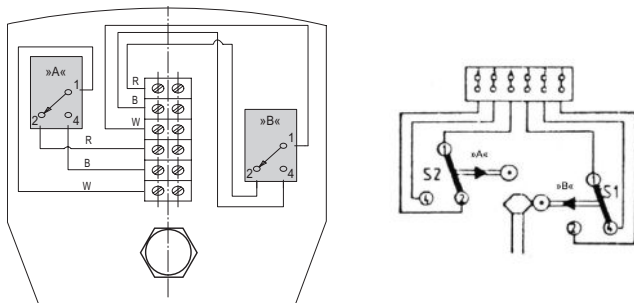

Switch type	VCSP	
	for limit switch design 1:	for limit switch design 2:
Type	–	024.85
Operating voltage	125–250 V AC	250 V AC
Maximum current	10 A (250 V AC); 3 A (24 V DC)	6 A
Protection class	IP 44	IP 65
Temperature	–20–60 °C	–20–60 °C

Circuit diagram – Inductive proximity switch NJ2-V3-N (2-wire, NAMUR)

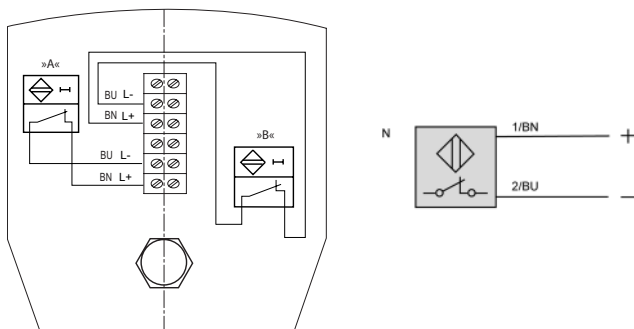

Switch type	NJ2-V3-N
Type	024.86
Switching function	NAMUR
Nominal voltage	8.2 V
Current consumption	1–3 mA
Switching frequency	0–1000 Hz
Protection class	IP 65
Temperature	–20–60 °C
ATEX marking, switch	II 1G Ex ia IIC T6...T1 Ga

Circuit diagram – Inductive proximity switch NBB2-V3-E2 (3-wire, PNP)

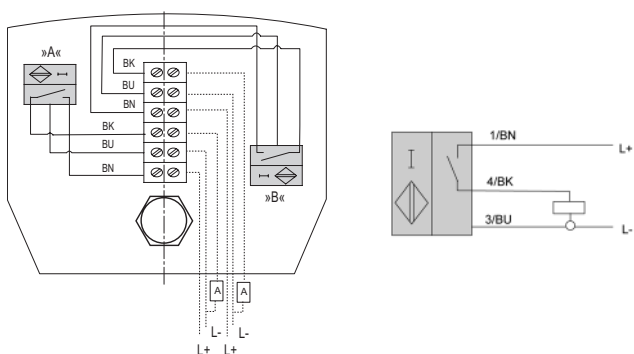

Switch type	NBB2-V3-E2
Type	024.87
Switching function	PNP
Operating voltage	24V DC (10–30V)
Output current max.	100 mA
Switching frequency	0–1000 Hz
Idle current	< 15 mA
Display	yellow LED
Protection class	IP 65
Temperature	–20–60 °C

Description

A	Connection »OPEN«
B	Connection »CLOSED«

Additional options Diaphragm valve MV 310

Limit switch

Limit switch design 1:

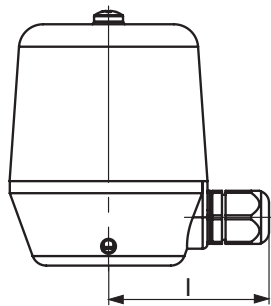
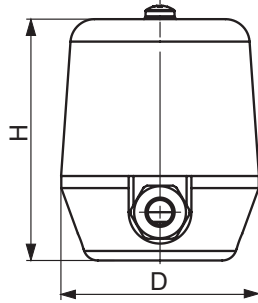

Type	VCSP	NJ2-V3-N	NBB2-V3-E2
D	82.0	82.0	82.0
H	100.0	100.0	100.0
l	64.0	64.0	64.0

all dimensions in mm / * dimensions in inch

Limit switch design 2:

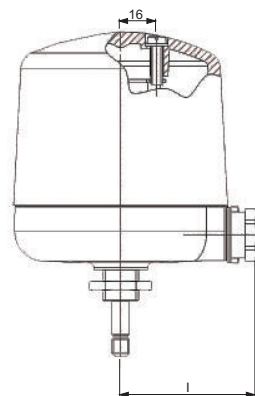
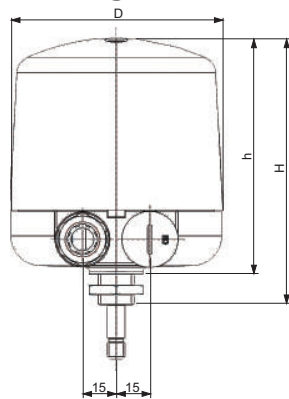

Type	VCSP	NJ2-V3-N	NBB2-V3-E2
D	95.0	95.0	95.0
h	106.0	106.0	106.0
H	120.0	120.0	120.0
l	60.0	60.0	60.0

all dimensions in mm / * dimensions in inch

Additional options Diaphragm valve MV 310

Limit switch

Accessories for design 2:

Adapter

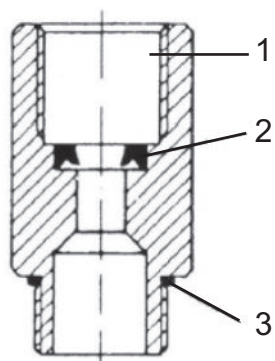

Position	Designation
1	Adapter
2	Grooved ring
3	O-ring

Attention

- For retrofitting onto NO valves, fit the adapter as an accessory.

Diaphragm valve MV 310 with hand wheel

Manual components DN 15–100

DN 15–50

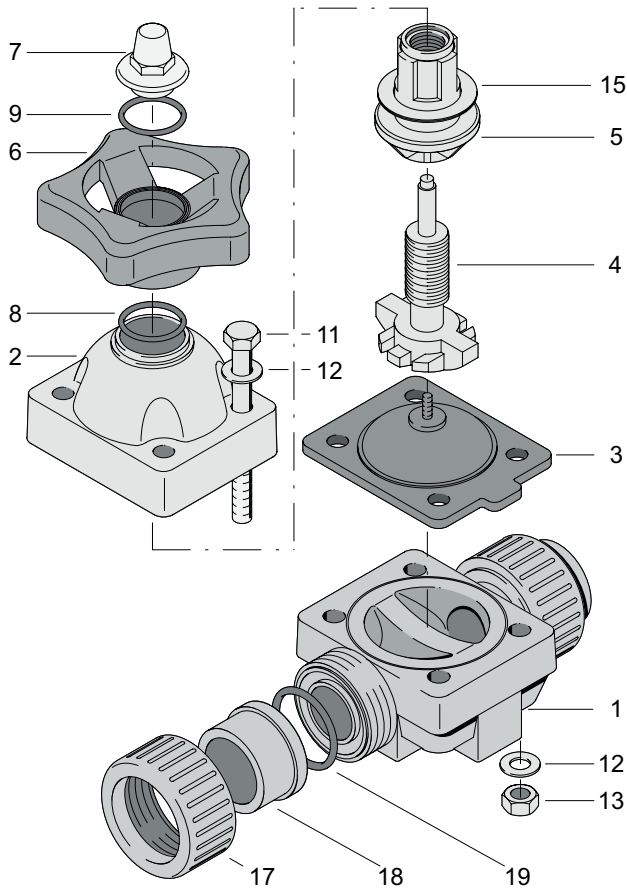

Position	Quantity	Designation
1	1	Valve body
2	1	Housing bonnet
3	1	Diaphragm
4	1	Spindle
5	1	Spindle nut
6	1	Hand wheel
7	1	Indicator cap
8	1	O-ring
9	1	O-ring
11	4	Hexagon nut
12	8	Washer
13	4	Hexagon nut
15	1	Bearing washer
17	1	Union nut
18	1	Union end
19	1	O-ring

DN 65–100

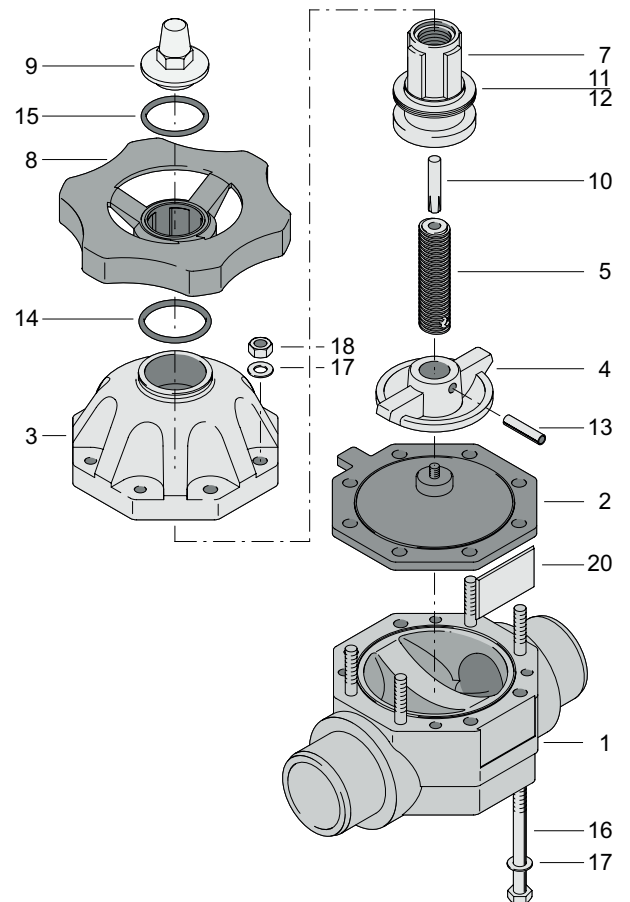

Position	Quantity	Designation
1	1	Valve body
2	1	Diaphragm
3	1	Housing bonnet
4	1	Pressure piece
5	1	Spindle
7	1	Spindle nut
8	1	Hand wheel
9	1	Indicator cap
10	1	Indicator pin
11	1	Axial bearing
12	2	Axial bearing washer
13	1	Clamping sleeve
14	1	O-ring
15	1	O-ring
16	4	Hexagon nut
17	8/12	Washer
18	4/8	Hexagon nut
20	1	Name plate

Diaphragm valve MV 310

pneumatic

Pneumatic components DN 15–50

Valve function NC without lift limitation

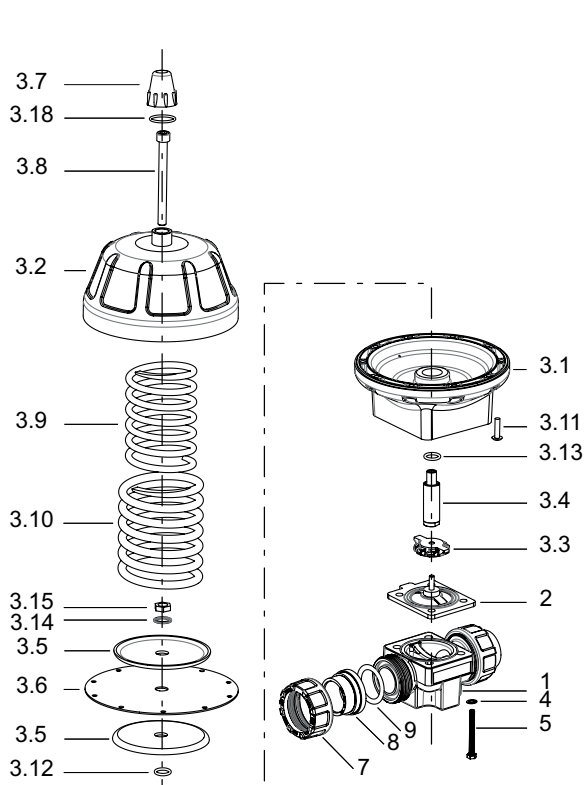

Valve function NC with lift limitation

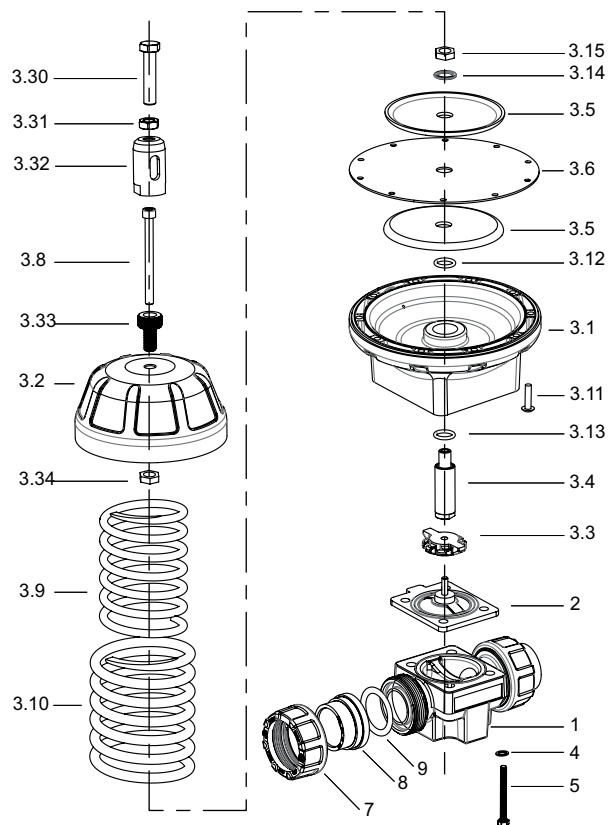

Position	without lift limitation	with lift limitation	Designation
1	1	1	Valve body
2	1	1	Diaphragm
3.1	1	1	Actuator housing UT
3.2	1	1	Actuator housing OT
3.3	1	1	Pressure piece
3.4	1	1	Actuator rod
3.5	2	2	Diaphragm disc
3.6	1	1	Diaphragm
3.7	1	–	Indicator cap
3.8	1	1	Adjustment screw
3.9	1	1	Pressure spring
3.10	1	1	Pressure spring
3.11	8/12	8/12	Cylinder screw
3.12	1	1	Circlip
3.13	1	1	Washer
3.14	1	1	Circlip
3.15	1	1	Hexagon nut

Position	without lift limitation	with lift limitation	Designation
3.18	1	–	O-ring
3.30	–	1	Hexagon screw
3.31	–	1	Hexagon nut
3.32	–	1	Lift limitation
3.33	–	1	Screw
3.34	–	1	Hexagon nut
4	4	4	Washer
5	4	4	Hexagon screw
7	2	2	Union nut
8	2	2	Union end
9	2	2	O-ring

Diaphragm valve MV 310

pneumatic

Components DN 15–50

Valve function NO

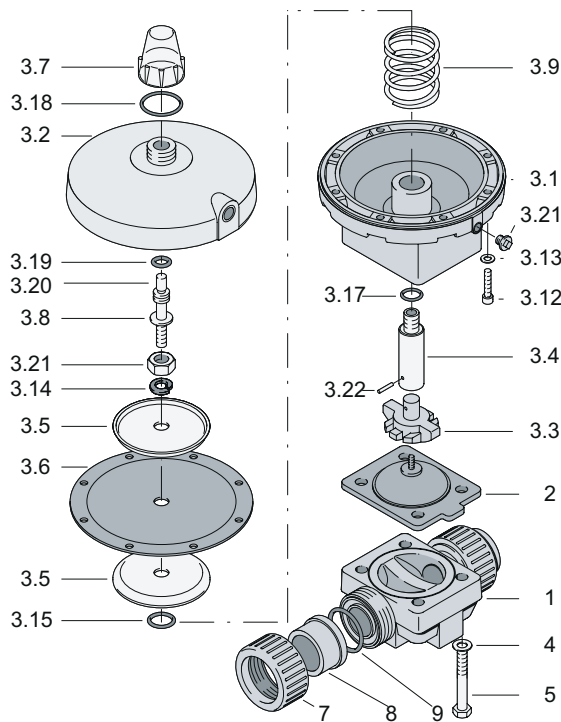

Valve function DA

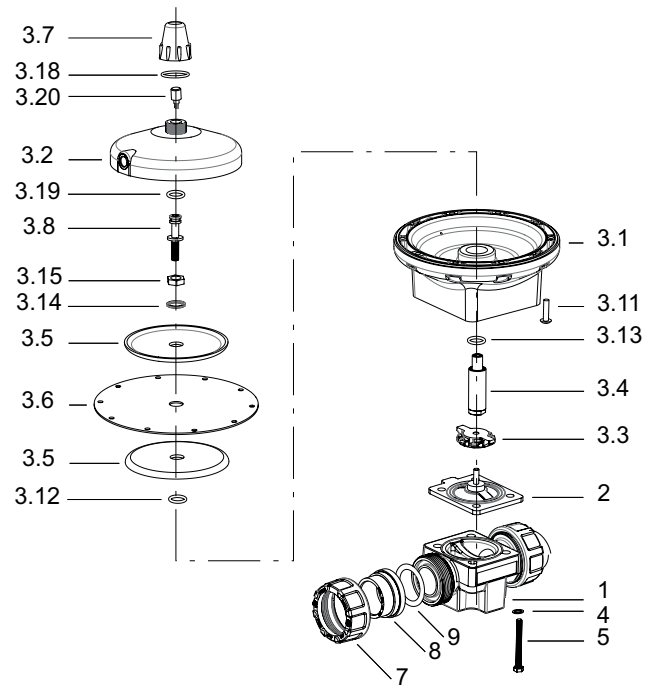

Position	NO	DA	Designation
1	1	1	Valve body
2	1	1	Diaphragm
3.1	1	1	Actuator housing UT
3.2	1	1	Actuator housing OT
3.3	1	1	Pressure piece
3.4	1	1	Actuator rod
3.5	2	2	Diaphragm disc
3.6	1	1	Diaphragm
3.7	1	1	Indicator cap
3.8	1	1	Adjustment screw
3.9	1	–	Pressure spring
3.11	8/10	8/10	Cheese-head screw
3.12	8/10	8/10	Cheese-head screw
3.13	1	1	Washer
3.14	1	1	Circlip
3.15	1	1	O-ring
3.17	1	–	O-ring

Position	NO	DA	Designation
3.18	1	1	O-ring
3.19	1	1	O-ring
3.20	1	1	Indicator pin
3.21	2	–	Hexagon nut
3.22	1	–	Clamping sleeve
4	4	4	Washer
5	4	4	Hexagon screw
7	2	2	Union nut
8	2	2	Union end
9	2	2	O-ring

Diaphragm valve MV 310

Pneumatic components DN 65

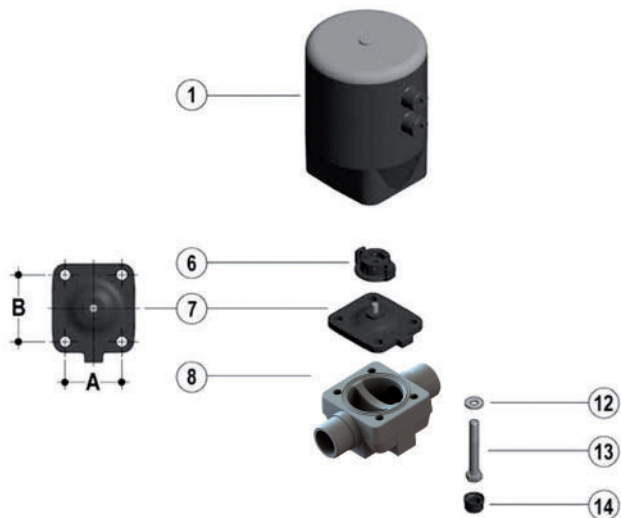

Position	Quantity	Designation
1*	1	Actuator
6	1	Compressor
7*	1	Diaphragm seal (EPDM, FPM, PTFE)
8*	1	Valve body (PVC-U, PP, PVDF)
12	4	Washer
13	4	Bolt
14	4	Protective earth plug (PE)
A	-	78.0 mm
B	-	82.0 mm

* Spare part

** Accessories

Diaphragm valve MV 310

Components DN 80–100

Valve function NC

DN 80

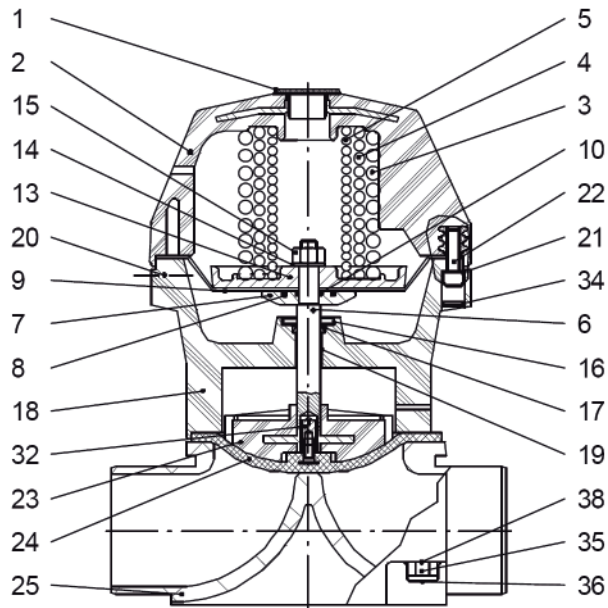

Position	Quantity	Designation
1	1	Plug
2	1	Actuator bonnet
3	1	Spring
4	1	Spring
5	1	Spring (not standard)
6	1	Spindle
7	1	Washer
8*	1	O-ring
9*	1	Control diaphragm
10*	1	O-ring
13	1	Diaphragm plate
14	1	Washer
15*	1	Stop nut
16*	1	Locking washer
17*	1	Sealing ring
18	1	Actuator bottom section
19	1	Slide bush

DN 100

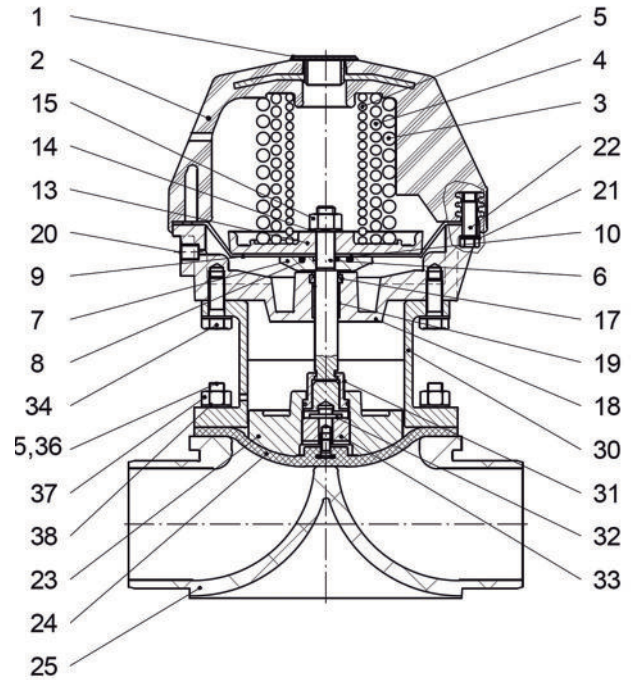

Position	Quantity	Designation
20	1	Plug for control air G 1/4"
21	12	Washer
22	12	Screw
23	1	Pressure piece
24	1	Diaphragm
25	1	Valve body
26	4	Washer
27	4	Screw
30	1	Wafer type flange
31	1	Coupling
32	1	Suspension, complete
33	1	Coupling
34	4	Screw
35	4	Screw
36	4	Stud bolt
37	8	Nut
38	8	Washer

* Spare part

Diaphragm valve MV 310

Components DN 80–100

Valve function NO/DA

DN 80

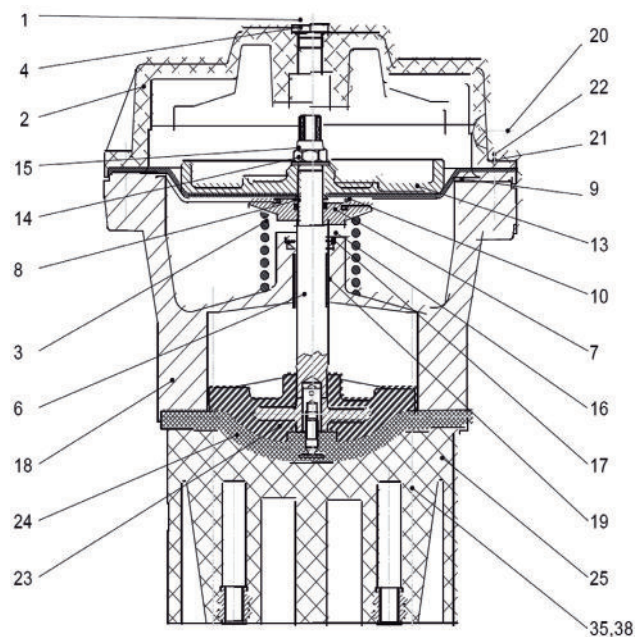

Position	Quantity	Designation
1	1	Threaded plug
2	1	Actuator bonnet
3	1	Spring
4	1	O-ring
5	1	Wafer type flange
6	1	Spindle
7	1	Washer
8*	1	O-ring
9*	1	Control diaphragm
10*	1	O-ring
13	1	Diaphragm plate
14	1	Washer
15*	1	Stop nut
16*	1	Locking washer
17*	1	Sealing ring

DN 100

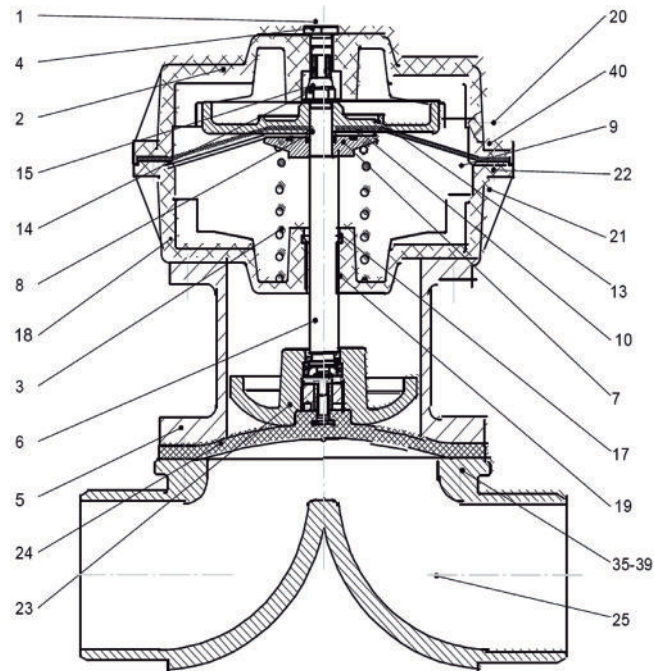

Position	Quantity	Designation
18	1	Actuator bottom section
19	1	Slide bush
20	1	Plug for control air
21	12	Washer
22	12	Screw
23	1	Pressure piece
24	1	Diaphragm
25	1	Valve body
35	4	Screw
36	8	Cover cap
37	4	Stud bolt
38	4	Washer
39	8	Nut
40	12	Nut

* Spare part