

# WAFER CHECK VALVE RSK 500

Nominal size DN 40–200

Nominal size 1 1/2"–8"

Pressure PN 5–8 bar



## Features

- narrow wafer flange version
- simple design
- O rings included in the scope of delivery for wafer type installation
- horizontal and vertical mounting
- optionally available with spring

## Additional options on demand

- Free of surface disturbing substances

## Attention

- Take the installation adapter for assembly into account
- Fit an installation adapter on the valve outlet side
- O-ring seal: Use welding stubs or flange adapters with flat jointing face
- Plan a settling zone of 5-10 x DN upstream and downstream of the valve
- Do not use valves without return spring for pulsating flows due to the formation of noise

[www.asv-stuebbe.com/produkte/armaturen](http://www.asv-stuebbe.com/produkte/armaturen)

# Pictogram Wafer check valve RSK 500

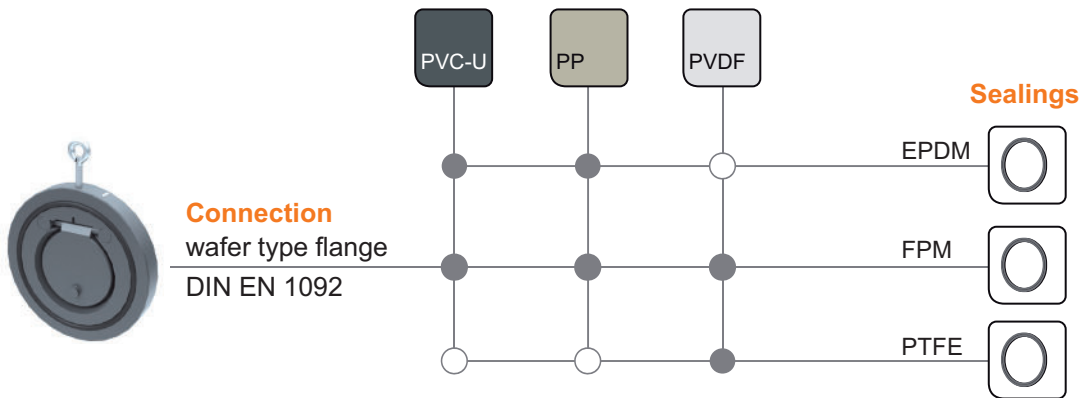

### Options:

Springs for horizontal installation



- 1.4571
- Hastelloy

Installation adaptors



- PVC-U
- PP
- PE
- PVDF

- available
- not available

### Basic normal size:

DN 8	DN 10	DN 15	DN 20	DN 25	DN 32	DN 40	DN 50	DN 65	DN 80	DN 100	DN 125	DN 150	DN 200	DN 250	DN 300	DN 350	DN 400
------	-------	-------	-------	-------	-------	-------	-------	-------	-------	--------	--------	--------	--------	--------	--------	--------	--------

## Wafer check valve RSK 500

### Application

- for regulation of a prescribed flow direction - backflow preventer

### Flow medium

- Neutral and aggressive fluid or gaseous media, provided that the valve components coming into contact with the media are resistant at the operating temperature in accordance with the ASV Stübbe resistance guide.
- Contaminated media may impair the sealing function.

### Flow direction

- Always in the direction of the arrow

### ASV Stübbe resistance guide

- [www.asv-stuebbe.de/pdf\\_resistance/300051.pdf](http://www.asv-stuebbe.de/pdf_resistance/300051.pdf)

### Nominal pressure (H<sub>2</sub>O, 20 °C)

- PN 5–8 bar

### Closing pressure

- Hermetically sealed at 0.3 bar

### Opening pressure

- See „Opening pressure“ table

### Version

- Wafer check valve without return spring for vertical pipes.
- Wafer check valve with return spring for horizontal pipes. Spring as accessories.

### Medium temperature

- See graphics „Pressure/temperature diagram“

### Operating pressure

- See graphics „Pressure/temperature diagram“

### Size

- DN 40–200

### Housing

- PVC-U, PP, PVDF

### Shut-off disc

- PVC-U, PP, PVDF

### Sealing element

- FPM, PTFE, EPDM

### Connection

- On the inlet side: with flange adapters or welding stubs according to DIN ISO with flat jointing faces
- On the outlet side: fit suitable installation adapters (see installation of adapter „Spigot“ / adapter „Spacer ring“) to ensure correct opening

### Mounting position

- vertical or horizontal, please note the direction of the arrow on the valve housing

### Color

- Housing: PVC-U, gray, RAL 7011
- Housing: PP, gray, RAL 7032
- Housing: PVDF, opaque, yellowish-white

### Accessories

#### Spring:

- made of stainless steel (1.4571) or Hastelloy (C4)

#### Installation adapter „Spigot“:

- Nominal pressure (H<sub>2</sub>O, 20 °C): PN 10
- Housing: PVC-U, PP, PE, PVDF
- Connection
  - Spigot end for solvent welding DIN ISO (PVC-U)
  - Spigot end for welding DIN ISO (PP), DIN ISO (PE), DIN ISO (PVDF)
- Color
  - PVC-U: gray, RAL 7011
  - PP: gray, RAL 7032
  - PVDF: opaque, yellowish-white
  - HDPE: black, RAL 9011

#### Installation adapter „Spacer ring“:

- Nominal pressure (H<sub>2</sub>O, 20 °C): PN 10
- Housing: PVC-U, PP, PVDF

### Attention

- Ensure that the valve disc makes contact with the inner wall of the fitting before it reaches the max. opening angle, otherwise there is a risk of breakage.
- Spring accessories: We also recommend this type for pulsating flow conditions.

## Pressure/temperature diagram for wafer check valve

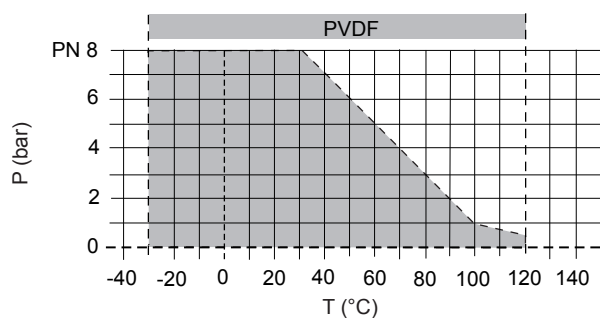
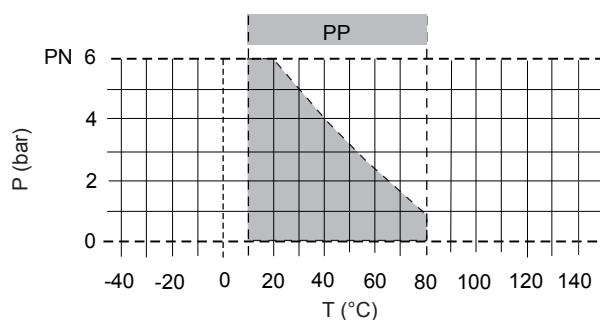
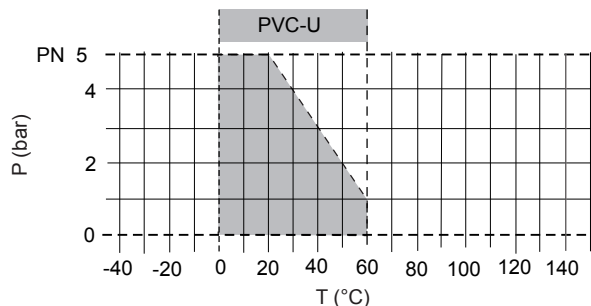

Description	
P	Operating pressure
T	Temperature

The pressure/temperature limits of the materials are valid for the stated nominal pressures and a service life of 25 years.

These values are guide values for flow medium types which do not negatively impact the physical and chemical characteristics of the valve material. It may be necessary to take diminution factors into consideration.

The operating life of the wear parts depends on the conditions of use.

# Wafer check valve RSK 500

## Pressure loss curve (standard values for H<sub>2</sub>O, 20 °C)

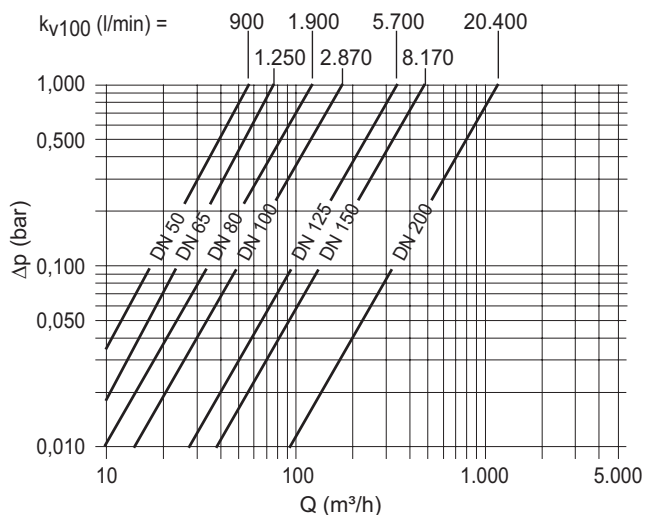

Description	
$\Delta p$	Pressure loss
Q	Flow

### Pressure loss and $k_v$ value

The diagram shows the pressure loss  $\Delta p$  in relation to the flow Q.

### Conversion formulas

$$c_v = k_v \times 0.07$$

$$f_v = k_v \times 0.0585$$

### Units

$k_v$  [l/min]

$c_v$  [gal/min] US

$f_v$  [gal/min] GB

## Opening pressure

Flow direction: from bottom to top

d (mm)		50	63	75	90	110	140	160	225
DN (mm)		40	50	65	80	100	125	150	200
RSK without spring	PVC-U	2	2	2	2	2	2	2	2
	PP	1	1	1	1	1	1	1	2
	PVDF	2	2	2	2	2	2	3	3
RSK with spring	PVC-U	22	22	22	22	22	22	22	22
	PP	21	21	21	21	21	21	21	22
	PVDF	22	22	22	22	22	22	23	23

all dimensions in mbar

# Wafer check valve RSK 500

Connection flange

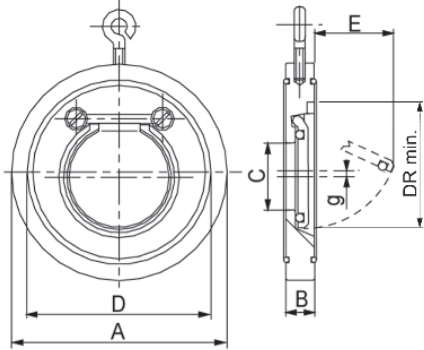

d (mm)	50	63	75	90	110	140	160	225
DN (mm)	40	50	65	80	100	125	150	200
DN (inch)	1 1/2	2	2 1/2	3	4	5	6	8
A	95.0	109.0	129.0	144.0	164.0	195.0	220.0	275.0
B	16.0	18.0	20.0	20.0	23.0	23.0	26.0	34.0
C	22.0	32.0	40.0	54.0	70.0	92.0	105.0	154.0
D	72.0	86.0	105.0	119.0	146.0	173.0	197.0	255.0
E	25.0	37.0	50.0	61.0	77.0	94.0	100.0	152.0
g	1.5	3.2	3.5	3.5	6.0	7.5	8.0	11.0
DR min.	43	54	70	82	106	131	159	207

all dimensions in mm / \* dimensions in inch

# Wafer check valve RSK 500

## Components

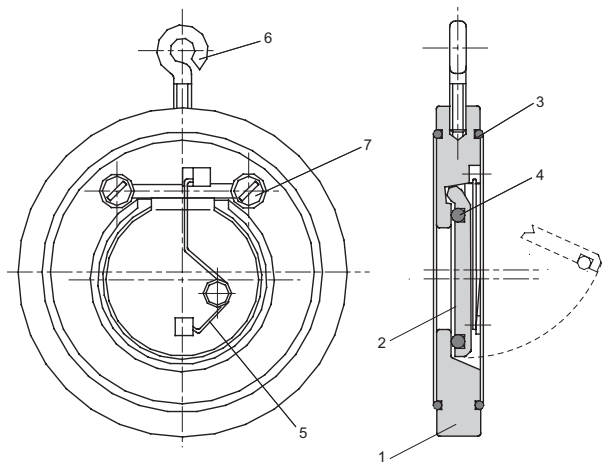

Position	Quantity	Designation
1	1	Housing
2	1	Shut-off disc
3	2	O-ring
4	1	O-ring
5	1	Spring
6	1	eyelet screw
7	2	Screw

\* Position 5 only for spring-loaded wafer check valve

## Installation

### Option 1: Installation adapter „Spigot“

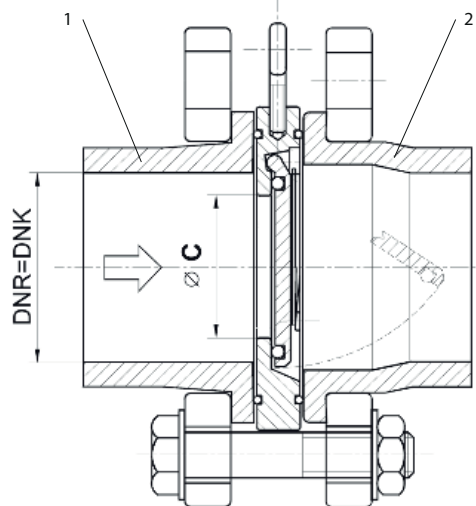

Position	Designation
1	Inlet side: Stub flange or collar bushing
2	Outlet signal: Installation adapter „Spigot“

### Option 2: Installation adapter „Spacer ring“

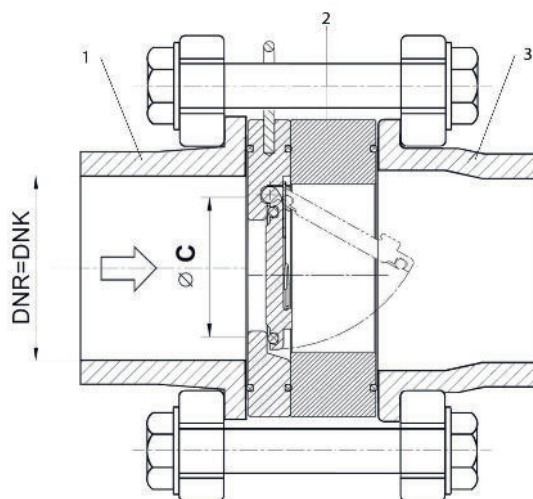

Position	Designation
1	Inlet side: Stub flange or collar bushing
2	Outlet signal: Installation adapter „Spacer ring“
3	Outlet signal: Stub flange or collar bushing

## Attention

For assembly on site, fit an installation adapter to ensure correct opening of the wafer check valve

### Accessories

#### Installation adapter „Spigot“

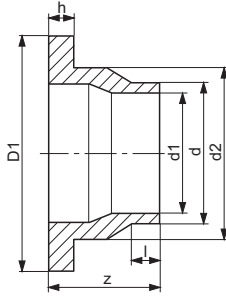

d (mm)	50	63	75	90	110	140	160	225
DN (mm)	40	50	65	80	100	125	150	200
DN (inch)	1 1/2	2	2 1/2	3	4	5	6	8
d1	40.8	51.4	61.0	73.6	90.0	114.0	130.8	184.0
d2	61.0	77.0	91.0	108.0	131.0	155.0	187.0	235.0
D1	90.0	105.0	125.0	140.0	160.0	190.0	215.0	270.0
h	12.0	14.0	16.0	17.0	18.0	25.0	25.0	32.0
l	PP/PE	10.0	10.0	15.0	15.0	18.0	20.0	25.0
	PVC-U	33.0	40.0	46.0	53.0	63.0	78.0	121.0
z	PP/PE	48.0	54.0	58.0	72.0	92.0	100.0	165.0
	PVC-U	71.0	84.0	89.0	110.0	137.0	188.0	261.0

all dimensions in mm / \* dimensions in inch

#### Installation adapter „Spacer ring“

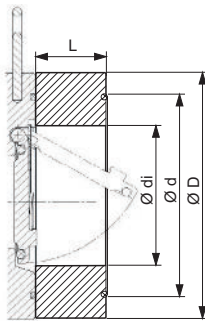

d (mm)	50	63	75	90	110	140	160	225
DN (mm)	40	50	65	80	100	125	150	200
DN (inch)	1 1/2	2	2 1/2	3	4	5	6	8
Ø di	43.0	54.0	70.0	82.0	106.0	130.0	158.0	206.0
Ø d	72.0	86.0	105.0	119.0	146.0	173.0	197.0	255.0
Ø D	95.0	109.0	129.0	144.0	164.0	194.5	220.0	275.0
L	20.0	25.0	40 <sup>1)</sup>	40 <sup>1)</sup>	50.0	50 <sup>2)</sup>	50.0	70.0

all dimensions in mm / \* dimensions in inch

<sup>1)</sup> PVDF = 30

<sup>2)</sup> PVDF = 40



# Wafer check valve RSK 500

## Accessories

### Pressure/temperature diagram for installation adapter „Spigot“ and „Spacer ring“

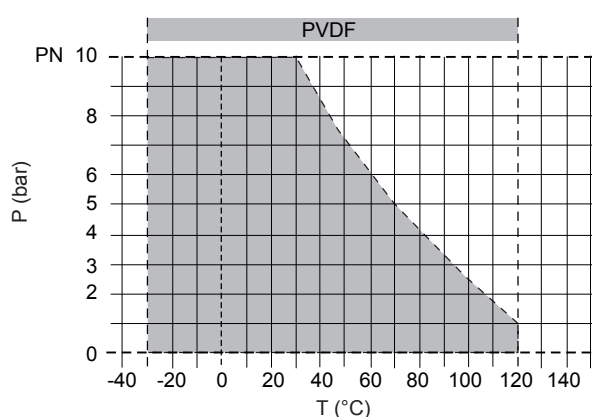
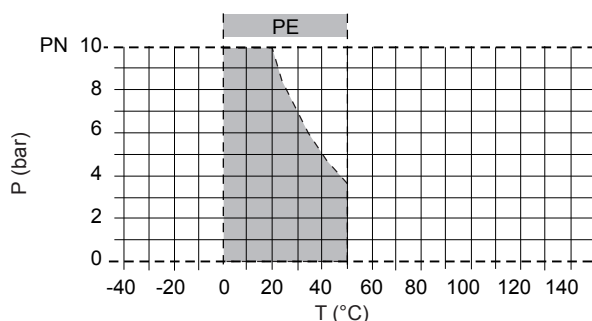
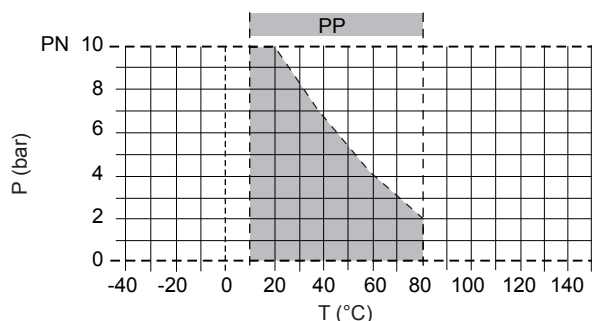
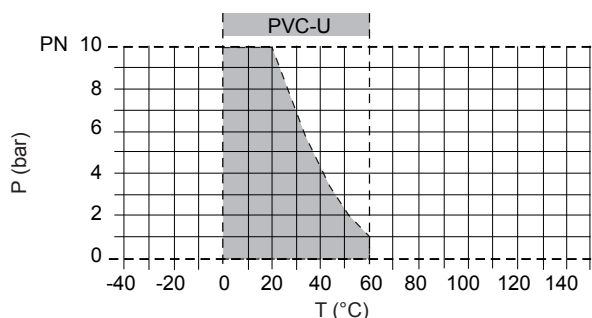

The pressure/temperature limits of the materials are valid for the stated nominal pressures and a service life of 25 years.

These values are guide values for flow medium types which do not negatively impact the physical and chemical characteristics of the valve material. It may be necessary to take diminution factors into consideration.

The operating life of the wear parts depends on the conditions of use.

#### Description

P	Operating pressure
T	Temperature